

# BTE SERIES

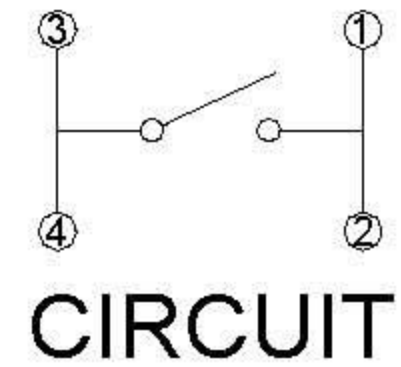

## DIMENSIONS

### BTE

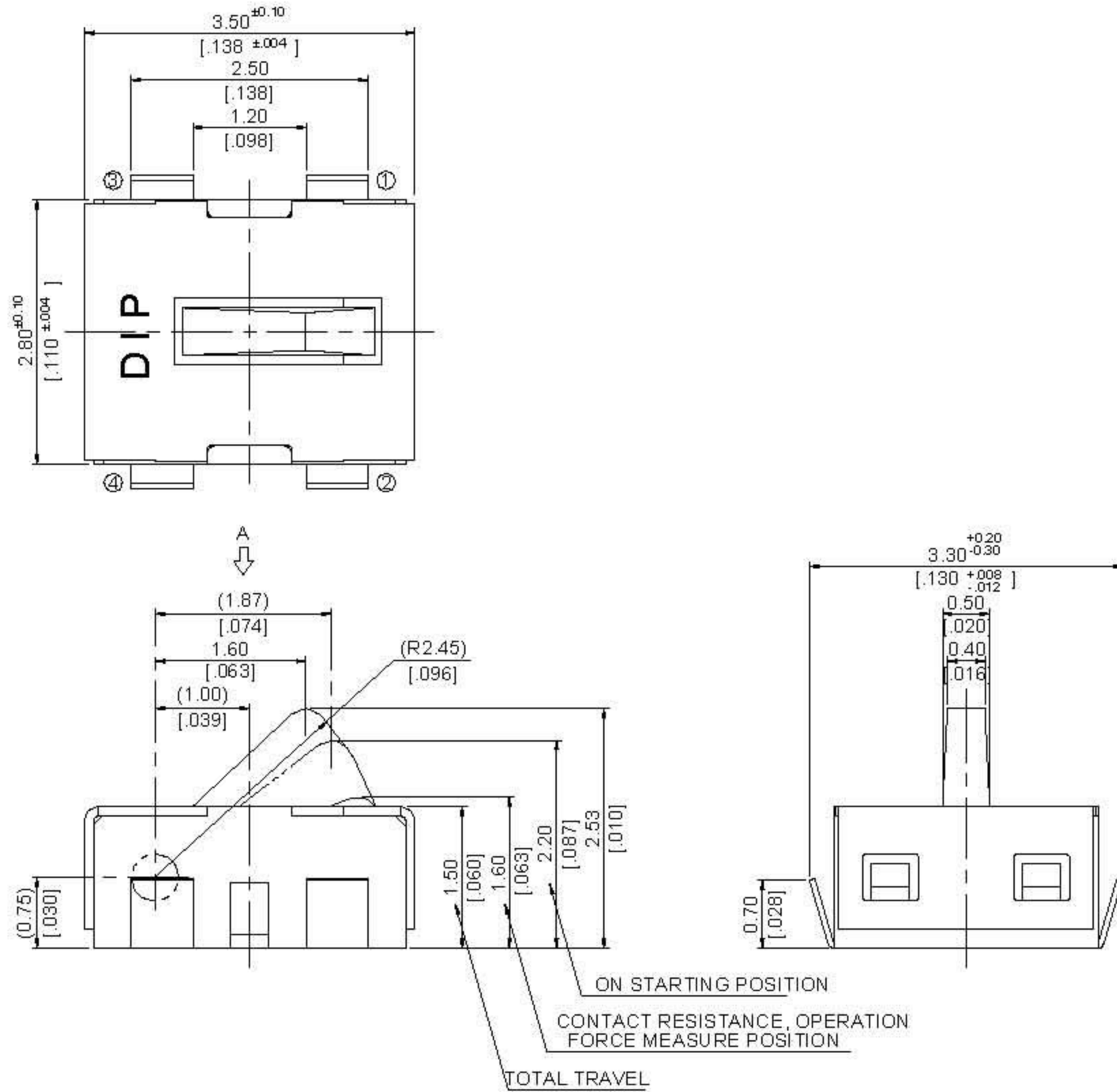

### P.C.B LAYOUT

(VIEW FROM THE DIRECTION A)

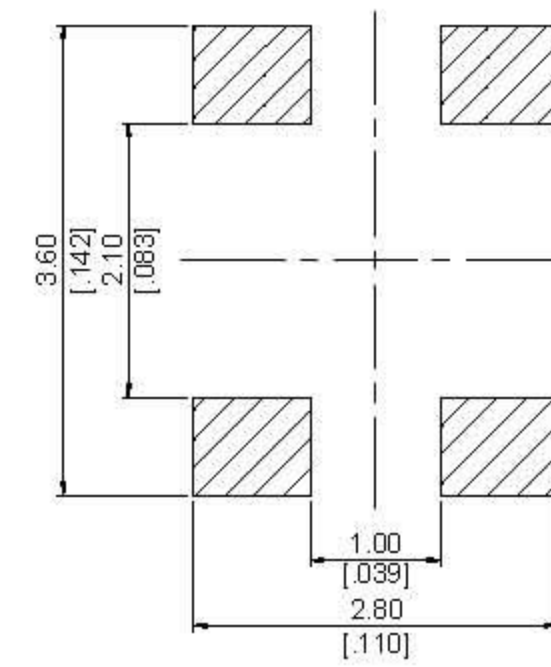

General Tolerance : ±0.2mm

### BTE-P

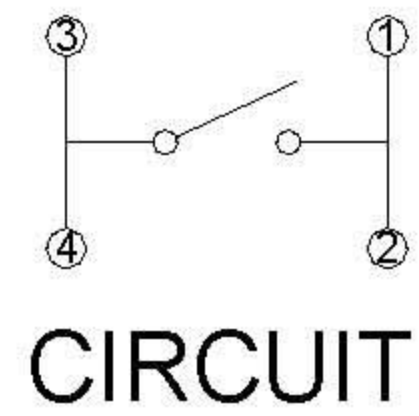
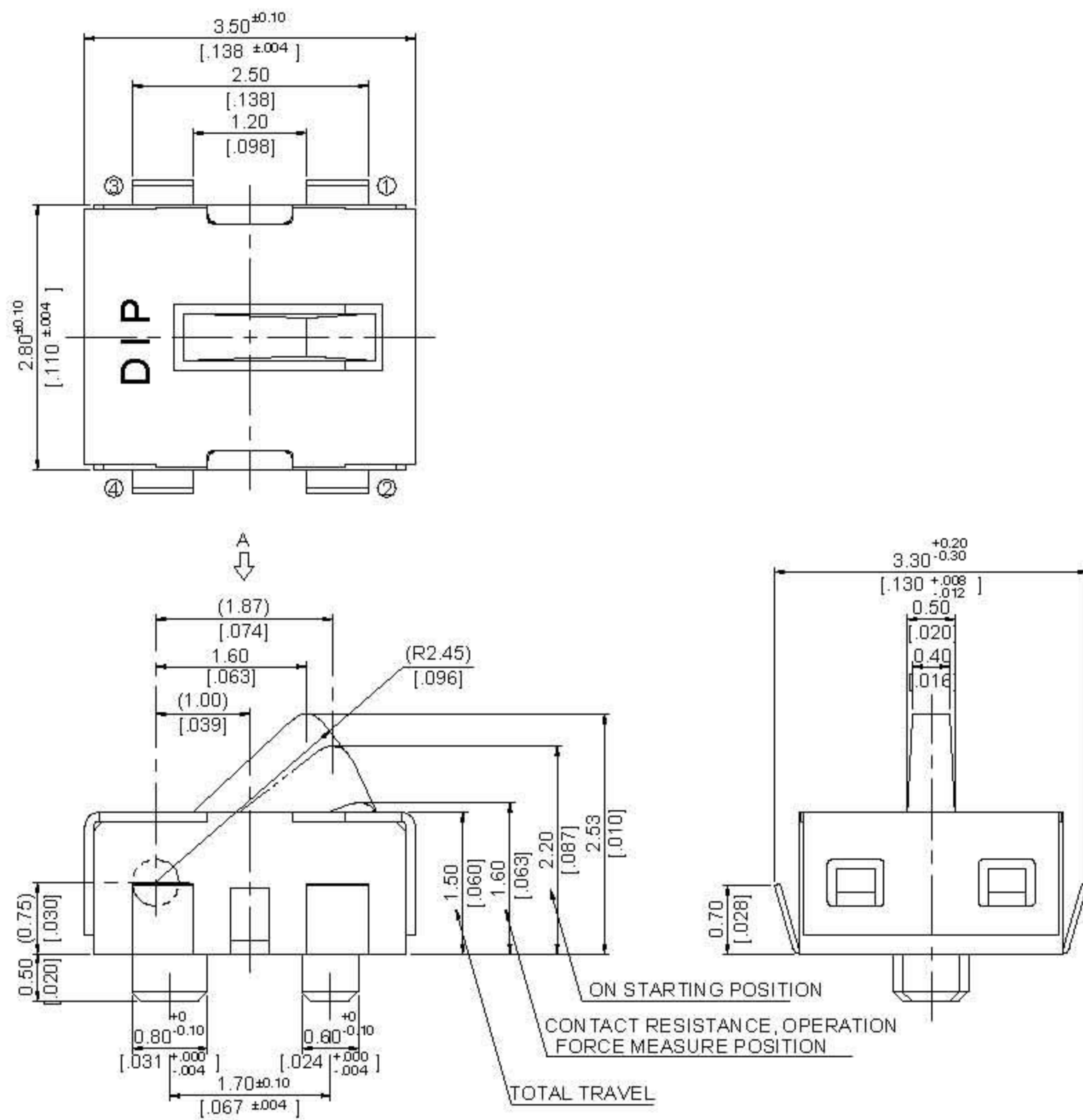

### P.C.B LAYOUT

(VIEW FROM THE DIRECTION A)

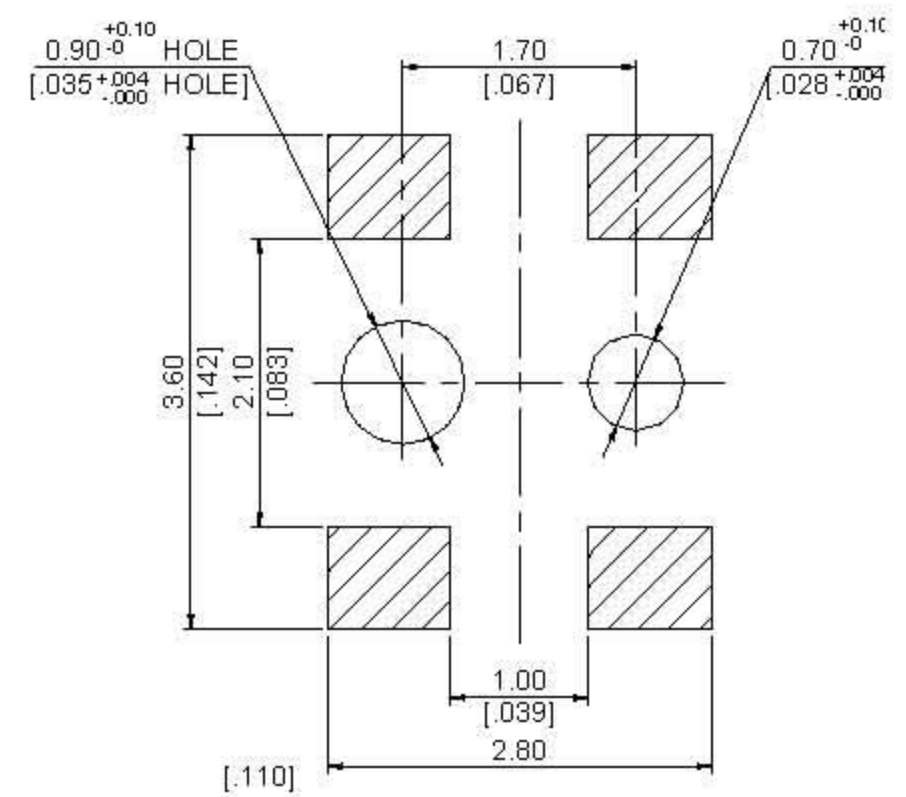

General Tolerance : ±0.2mm

# HOW TO ORDER

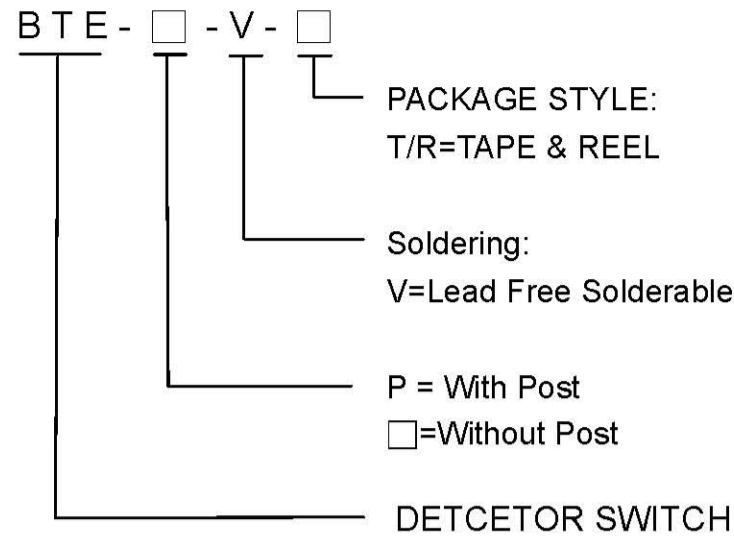

## SPECIFICATION

### △MECHANICAL

Operation Force : 50gf Max.  
Stroke : 1.03mm MAX.  
Operation Temperature Range : -10°C to +60°C  
Storage Temperature Range : -20°C to +70°C

### △ELECTRICAL

Electrical Life : 100,000 cycles  
Rating : 1 mA , 5 VDC  
Contact Resistance : 2Ω Max.  
Insulation Resistance : 100 MΩ Min , at 100 VDC.  
Dielectric Strength : 100 VAC / 1 minute.  
Contact Arrangement 1 pole 1 throw

## MATERIAL

△COVER : Stainless steel.  
△CONTACT : Phosphor bronze with silver plated.  
△TERMINAL : Brass with silver plated.  
△BASE : LCP High-Temp. Thermoplastic.  
Color : Black  
△STEM : LCP High-Temp. Thermoplastic.  
Color : Black

## SOLDERING PROCESSES

For best results, please follow these recommendation:

△HAND SOLDERING : Use a soldering iron of 30 watts, controlled at 350°C approximately max 5 seconds while applying.

△REFLOW SOLDERING: When applying reflow soldering, the peak temperature or the reflow oven should be set to 260°C max.

△Reflow Temperature Profile:

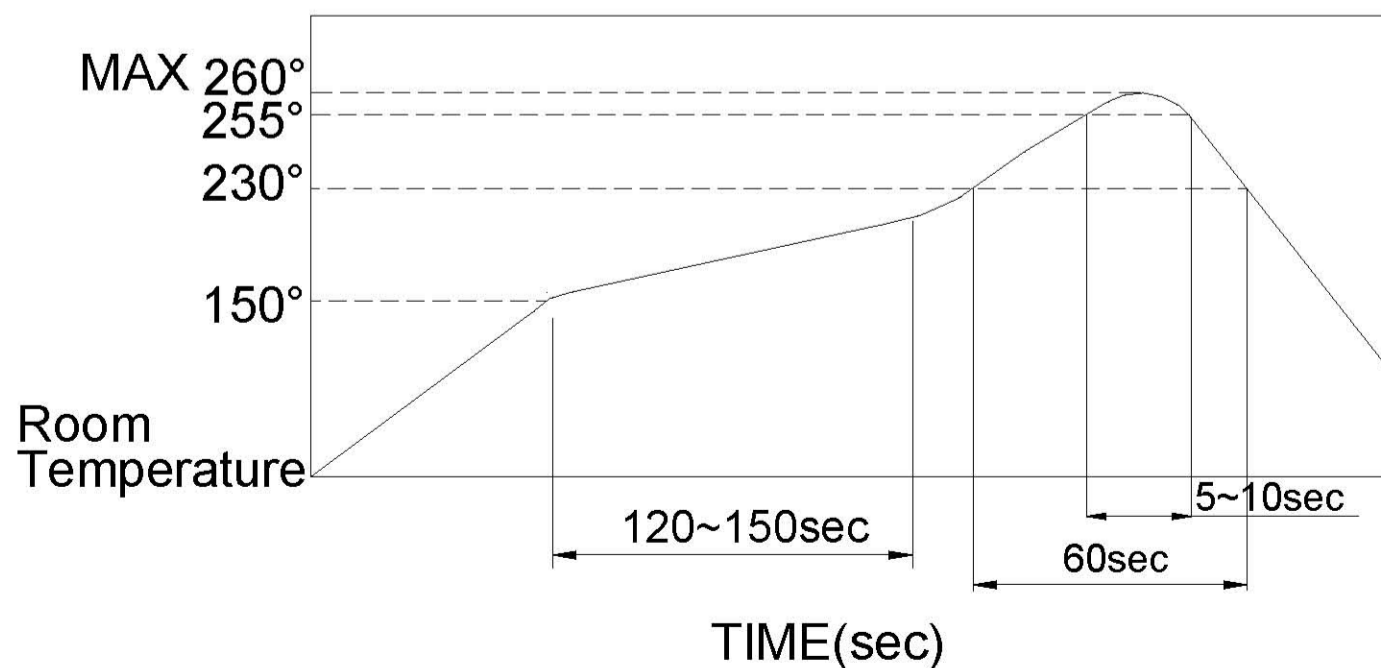

# PACKING

REEL	Part Number	Number Per Tube	Number Per Reel
	BTE	-	2600
BTE-P	-	2600	

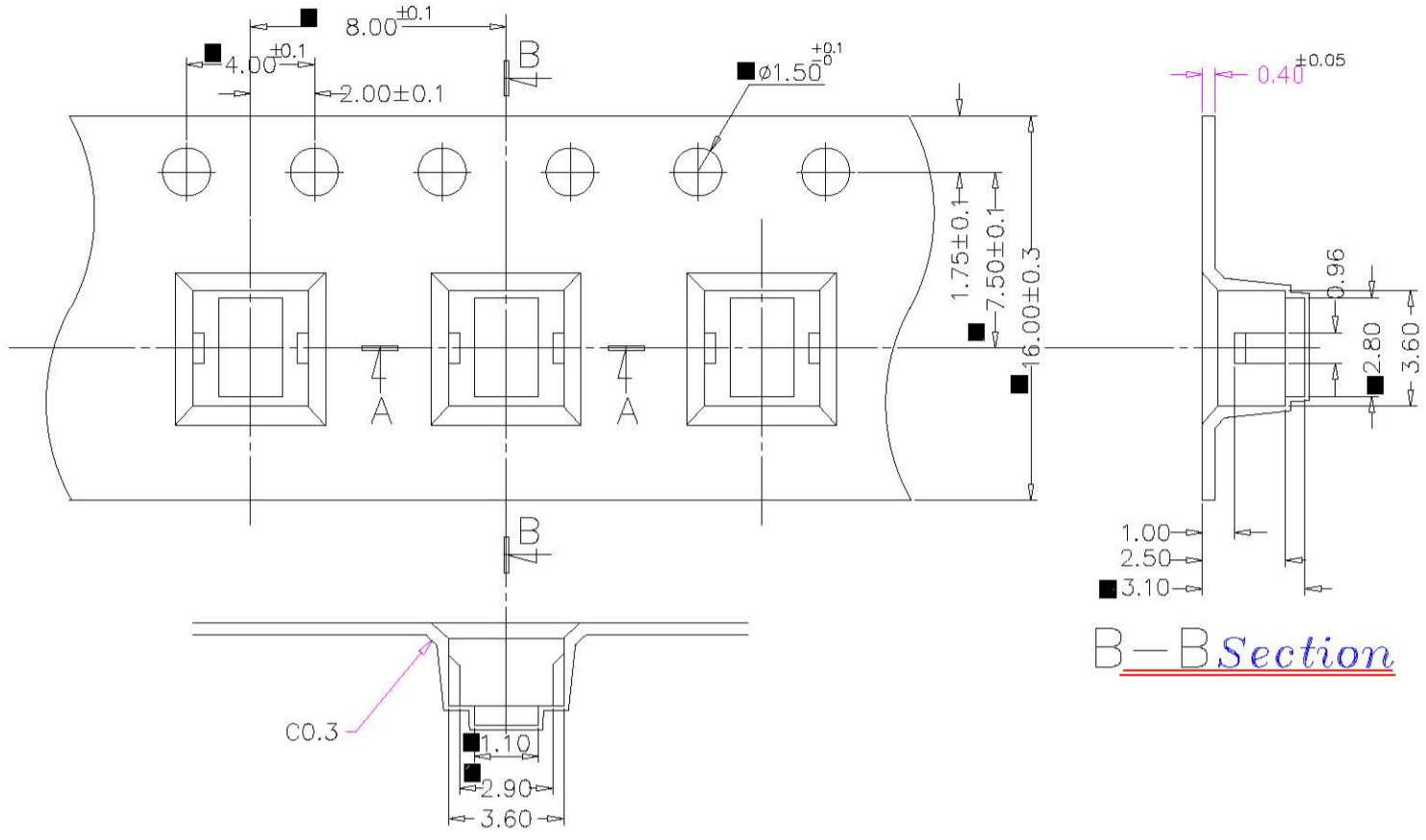

A-A Section

B-B Section

General Tolerance : ±0.1mm